

The VOITH logo is positioned in the top right corner of the white header area. It consists of the word "VOITH" in a bold, blue, sans-serif font. The background of the entire cover is a dark blue network of glowing nodes and connecting lines, creating a sense of digital connectivity and technology.

**VOITH**

MAGAZINE FOR HYDROPOWER TECHNOLOGY

# HyPower

#27 | Spring 2016

BRINGING INDUSTRIE 4.0 TO THE HYDROPOWER INDUSTRY

## FUTURE-READY

GLOBAL EXPERTISE  
TRANSFORMING HYDRO THROUGH AUTOMATION

AGENDA SETTING  
SERVICES FOR TODAY AND TOMORROW

**IMPRINT****Publisher:**

Voith GmbH  
St. Pöltener Str. 43  
89522 Heidenheim  
Germany  
www.voith.com

**Responsible for the publisher:**

Ute Böhringer-Mai

**Editor-in-chief:**

Gudrun Köpf

**Editorial Team:**

Elke Kleinknecht, Susanne Speiser, Dr. Vesna Stirnadel

**In cooperation with:**

C3 Creative Code and Content GmbH,  
Heiligegeistkirchplatz 1, 10178 Berlin, Germany  
www.c3.co

Shareholders of C3 Creative Code and Content GmbH are the Burda Gesellschaft mit beschränkter Haftung (limited liability company), Offenburg, and the KB Holding GmbH, Berlin, with 50% each.

Sole shareholder of the Burda Gesellschaft mit beschränkter Haftung is the Hubert Burda Media Holding Kommanditgesellschaft (limited partnership), Offenburg. Shareholders of KB Holding GmbH are Lukas Kircher (managing director, Berlin) and Rainer Burkhardt (managing director, Berlin) with 50% each.

**Paper:**

HyPower is printed on Respecta Silk. This paper was produced on a Voith paper machine.

**Copyright:**

No part of this publication may be copied, reproduced or otherwise disseminated, nor may any of the content in it be used in part or in whole in other works in any form whatsoever, without express written permission of the editor.



**YOUR FEEDBACK:** If you have any comments or questions on this issue of HyPower, please contact us: [hypower@voith.com](mailto:hypower@voith.com)

**Photographs:**

Cover: shutterstock/123dartist, P. 8/9: Connie Zhou/Action Press, p. 11: Dawin Meckel, Berlin (right), Rüdiger Nehmzow, Düsseldorf (above), p. 15/16: Christian Wesser, Heidenheim, p. 17: Dawin Meckel, p. 24: Manfred Georg Schwellies, Hohenlockstedt, p. 32: Dawin Meckel (above), p. 33: Rüdiger Nehmzow (above), p. 34: Hayman Studios, York (PA) USA, p. 35: Christian Wesser, p. 36: Rüdiger Nehmzow, p. 40/41: Getty Images/Prakash Singh, p. 44: Getty Images, p. 45: Stocksy

All other photos are from Voith.



## KEEPING THE ENERGY FLOWING

**In the 21st century, the demand for power is always on.** For power producers that means reliability is key. Automation systems and plant services are therefore of highest importance, and especially when it comes to hydropower, because plants are often located in remote locations, without easy access. Of course, automation and services have always been important in any hydropower project, and many decades-old skills and technologies are still vital today. However, change is on the horizon.

“Industrie 4.0” or the “Internet of Things” promises to take automation and service to the next level, by providing constant streams of operational data that can be analyzed remotely, and used to better predict maintenance needs. You might ask yourself what are the benefits related, since new solutions require investments. It’s the reduced risk of breakdowns, hence less downtime, higher plant reliability and more flexible operating modes.

Voith is driving progress for its customers in this new era of Industrial IT through the

establishment of its new Digital Solutions division, which took place 1 April 2016.

This new division is the perfect complement to the proven set of hydropower products, services and integrated plant solutions that Voith Hydro offers. The combination of state-of-the-art automation innovation, and services that are rooted in deep expertise developed over almost 150 years, will help our customers take advantage of the newly connected world, while at the same time ensuring the safety and integrity of their hydropower plants.

This new edition of HyPower provides insight into exactly how this is being achieved. Enjoy the read!

Yours sincerely,

Ute Böhringer-Mai  
Vice President Global Market Communication



Join us on Twitter:  
[https://twitter.com/voith\\_hydro](https://twitter.com/voith_hydro)





8

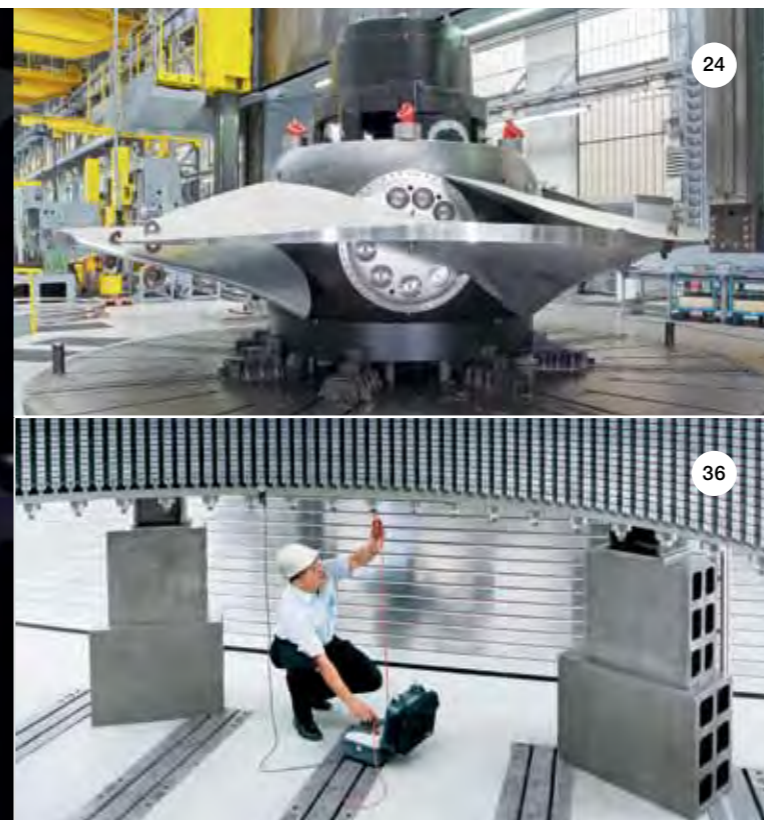

24



40



Discover more about Voith through its other insightful publications.

**AGENDA SETTING**

8 **BUILDING A SMARTER PLANT**  
Insight into how Voith is working with its customers to shape the application of Industrie 4.0 within the hydropower sector

14 **MANAGEMENT INTERVIEW**  
The outgoing and incoming CEOs of Voith Hydro discuss the company's future

17 **COLLABORATION IS ALL**  
How teams work together to solve customer challenges

18 **ALWAYS UP AND RUNNING**  
Extending plant life and minimizing downtime for hydropower operators

20 **DEEP EXPERTISE**  
The extraordinary breadth and depth of Voith's portfolio

22 **TRAINING THE NEXT GENERATION**

Voith Hydro School is ensuring a bright future for hydropower engineering

**GREEN ENERGY MIX**

24 **MORE STABILITY, LESS WEAR**  
Innovative control technology supports grid stability by ensuring a smooth flow of power

**FULL-LINE SUPPLIER**

26 **THE POWER OF INTEGRATION**  
Today, hydropower operators demand complete plants, not just machinery

27 **LESS IS MORE**  
The significance of standardization at the Dakter power plant in the Vietnamese mountains

**FROM THE ARCHIVES**

28 **MILESTONES IN TURBINE GOVERNOR DEVELOPMENTS**  
From the invention of the first governor in the 19th century, to the latest digital versions

**GLOBAL EXPERTISE**

30 **AUTOMATION IN ACTION**  
How automation technology streamlines hydropower plant operation around the world

34 **SERVICE HEROES**  
Two service specialists provide very different perspectives on an essential role

36 **COMPREHENSIVE COMPETENCE**  
How a history of acquisitions and joint ventures benefits Voith Hydro customers

**SUCCESSFUL PARTNERSHIPS**

40 **NATURAL POWER**  
The breathtaking Salal hydropower plant in the North of India

**INNOVATION**

42 **MIND THE GAP**  
All about the latest innovations in narrow gap welding

**GUEST PERSPECTIVE**

44 **WORKING OUT WATER SHORTAGE**  
Why measuring the sustainability of groundwater is an issue of global importance

**REGULARS**

- 03 EDITORIAL
- 06 WHAT'S NEW
- 07 ON TOPIC
- 43 WORLD OF VOITH
- 46 5 QUESTIONS FOR ...
- 47 GLOBAL VIEW





## SMOOTH TRANSITIONS AT THE TOP

In October 2015 and January 2016, **important changes took place in the Boards of Management at Voith Group and Voith Hydro** that will power the future success of Voith and its customers.

### NEW CEO – UWE WEHNHARDT

After a successful stint as CEO of the Group Division Voith Hydro, Dr. Roland Münch has become CEO of the new Group Division Voith Digital Solutions, which will oversee the development of innovative digital business models for the entire Voith Group. Replacing him as CEO of Voith Hydro is Uwe Wehnhardt, an industrial engineering graduate with a long track record of management success at major international enterprises such as Procter & Gamble and Alfred Kärcher GmbH & Co. KG. Previously Executive Vice President at Voith Paper Rolls, and appointed as a Member of the Management Board of Voith Hydro in 2011, Mr. Wehnhardt brings a combination of profound technical know-how and a deep understanding of customer needs to the role.



Uwe Wehnhardt



Dr. Tobias Keitel



Martin Andrä

Group and MAN Ferrostaal AG before joining Voith Hydro as a project manager in 2011. He held various management positions before being appointed Head of the Business Unit for new Large Hydro projects in 2014.

### NEW COO – DR. TOBIAS KEITEL

Following Mr. Wehnhardt as Chief Operations Officer of Voith Hydro will be Dr. Tobias Keitel, who studied industrial engineering and holds an MBA. Previously, he was with Boston Consulting

### NEW CMO – MARTIN ANDRÄ

Following the retirement of his predecessor Jürgen Sehnbruch in September 2015, Martin Andrä has been appointed as Voith Hydro's new Chief Market-

ing Officer. Having held various senior management positions at Siemens AG in Erlangen and Brazil for 17 years, Mr. Andrä joined Voith Siemens Hydro Kraftwerkstechnik GmbH & Co. KG in 2000, and was made Chairman of the Board in 2003. Following a successful period as CEO of Voith Hydro Shanghai Ltd. in China, he has now been appointed a Member of the Management Board at Voith Hydro, with global responsibility for Sales and Marketing. //

## SUPPORTING ECONOMIC GROWTH

**INDIA** Attended by none other than the Prime Minister of India, Narendra Modi, the inauguration of the Baglihar II hydroelectric project in Jammu and Kashmir state took place on 7 November 2015. It marked the completion of a two-site, 900 MW hydropower project that is vital to the future economic and social prospects of this energy-deficit state. Led by Voith Hydro, the consortium responsible for the supply, construction and commissioning of the plant delivered the project on time, despite severe geological and climatic challenges during its execution. //



## POWER ON A HUGE SCALE

**From turbine revolutions to the data generated and power output,** hydropower produces some pretty big numbers. And in the future, those numbers will just keep going up!

### 1 Round and round

On average, a Francis turbine completes 50,000,000 revolutions per year

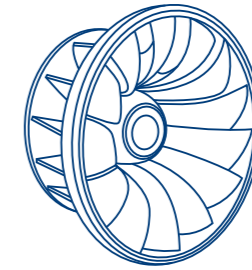

50,000,000 revolutions

### 2 Big data

The sensors in a single hydropower plant produce 3.5 terabytes of data per year.

3.5 terabytes (TB) equates to a log book containing 1,750,000,000 DIN A4 pages.

A person would need 4,000 years to read through this data.



3.5 TB

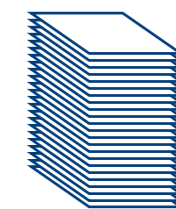

1.75 bn  
DIN A4 pages

4,000 years



### 3 Ring, ring

Over the course of a year 2 billion smartphones need 2,000,000,000 kWh.



2 bn smartphones



2 bn kWh

### 4 Hydropower production

The Three Gorges Dam in China produced 98.8 billion kWh of energy in 2014.

98.8  
bn kWh

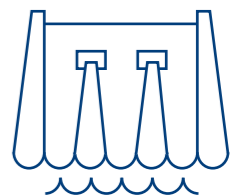



# BUILDING A SMARTER PLANT

Collecting and analyzing large volumes of data creates value for Voith and its customers.

Industry 4.0 is more than a buzzword – it's a revolution. In fact, it's the fourth in a series of revolutions that began in the 19th century with the move from farms to factories, continued in the early 20th century with electrification and mass production, and progressed to digital automation in the 1960s and 1970s. Industrie 4.0, or the Internet of Things, marks the era of industrial digitization. It's defined by: machines communicating autonomously with other machines; the use of sensors in machinery to collect huge volumes of data; the rapid analysis of that data to produce actionable insight for decision-making; the use of consumer information and communication technology (ICT) in an industrial >



▷ environment; and establishing a communications infrastructure that supports data and insight distribution, as well as action. And the potential business value is significant.

Ultimately, that value can be measured in the use of digital technology to make industrial systems of all kinds – from manufacturing to plant operation – more efficient, reliable and secure, thereby reducing risk and cost. But it can also open the door to new service-based business models focused on, for example, the ability to predict equipment failures before they happen. In the hydropower sector, the Internet of Things offers Voith Hydro and its customers a wealth of new possibilities. Specifically, Industrie 4.0 solutions have the potential to help plant operators: increase plant availability; reduce maintenance/servicing cost and effort; and reduce cost and risk through increased infrastructure safety and security.

**Long-term opportunities**

The opportunities generated by the Internet of Things are exciting. But taking advantage of them requires a complete change of mindset and approach within the hydropower industry. Let's take maximizing the operational efficiency of a turbine through maintenance as an example.

A "1.0" approach to this issue would be to run the turbine to failure, shut it down, dismantle and rebuild it, and then return it to operation. This is clearly a slow and expensive operation in terms of the repair itself, the manpower required, and the power generation time lost.

The typical preventative ("2.0") approach used today is to follow a fixed period maintenance schedule and perform repairs or replace parts even if it is not strictly necessary – the equivalent of replacing a car tire after a fixed number of kilometers. This approach is a step forward, but still not optimal, because it

does not maximize the return on every component.

Condition-based maintenance ("3.0") improves on this scenario by using sensors to constantly measure the condition of the machinery, so that problems can be identified and resolved quickly. This saves time and money, because it eliminates the need to employ a team of engineers to take the machinery apart, in order to assess its condition accurately.

Finally, predictive maintenance is the true Industrie 4.0 approach. If the combination of different sensor data, distributed digitally to smart analytics systems, indicates a high chance of component failure in, for example, three weeks, an operator could: receive a recommendation to change the turbine's mode of operation to extend that period to five weeks; order the required spare part, which has a delivery time of four weeks; shut down the turbine after four weeks and six days, replace the part, and start operation again immediately. This

kind of "just-in-time repair" provides a perfect example of how Industrie 4.0 will allow hydropower operators to utilize new technologies, while simultaneously extracting maximum value from the infrastructure they already have. Indeed, maximizing long-term operational efficiency and ROI will, in the future, be as much about leveraging data and software services that prolong the life of existing infrastructure, as it will be about large capital investments in new machinery.

**The Digital Solutions difference**

Voith believes that taking advantage of Industrie 4.0 is a challenge that should be faced and mastered together with its customers. The Task Force Industrie 4.0 at Voith Hydro, which has now become part of Voith Digital Solutions, is pioneering the development of smart solutions in the hydropower industry. Felix Flemming, the head of the Task Force, and now a key member of the ▷



Control room and equipment



“Smart Services can help maximize hydropower’s contribution to the energy mix by delivering cost and efficiency benefits.”

Dr. Felix Flemming  
Voith Digital Solutions



## THE SECURITY OF SEPARATION

Hydropower plants represent critical societal infrastructure. Smart services require the establishment of new digital communication channels between plants, factories, and the cloud, which are potentially vulnerable to a wide range of hacking attacks. The potential security risks must therefore be taken extremely seriously. After all, the potential consequences of a criminal or terrorist group taking control of a hydropower plant, for example, near a population center, are extremely critical. One of the ways that Voith Hydro addresses this issue is through the consequent separation of plant control and smart service communication channels. This ensures that, should a security breach occur within the data collection and distribution network, the integrity of the plant's control systems cannot not be compromised. In this sensitive area, Voith has years of experience through the certified Remote Support Server, which enables secure access to a large number of paper machines and hydropower plants. In addition, the in-house IT organization supports not only Voith's own organization, but also external customers with respect to the "Security and Privacy" of their global IT infrastructure.

▷ Digital Solutions team, explains what makes Voith's approach so special: "Our approach to applying Industrie 4.0 to hydropower focuses on developing smart solutions that help our customers make the most of the operational, cost and security benefits that digitization can deliver. We use agile processes to ensure that we can move from discussion to concept, prototype and installed solution as quickly as possible. But most important, is that the customer's requirements and preferences are always at the center of every project."

This flexibility is characteristic of how the Voith Digital Solutions team goes about its work. The development of new solutions is cross-functional and the Industrie 4.0 team members were deliberately selected to provide a broad

mixture of experience and talent, as Flemming explains: "We selected new graduates, experienced engineers, software experts, process mavens, commissioning specialists and other talented people to give us multiple perspectives on customers' challenges. Not only that, we have the freedom to explore ideas thoroughly and do things a little differently, even if that means pushing boundaries. But whatever we do, our focus is always on what is most important to the customer."

In many ways, this approach represents the perfect combination of a US-style "trial and error" development process, with the methodical approach to engineering for which Voith and many other German companies are famous. It's also extremely agile, as Felix



1 Capim Branco power station, Brazil.  
2 Cross-functional teams ensure an optimal result.  
3 Smart plant construction.

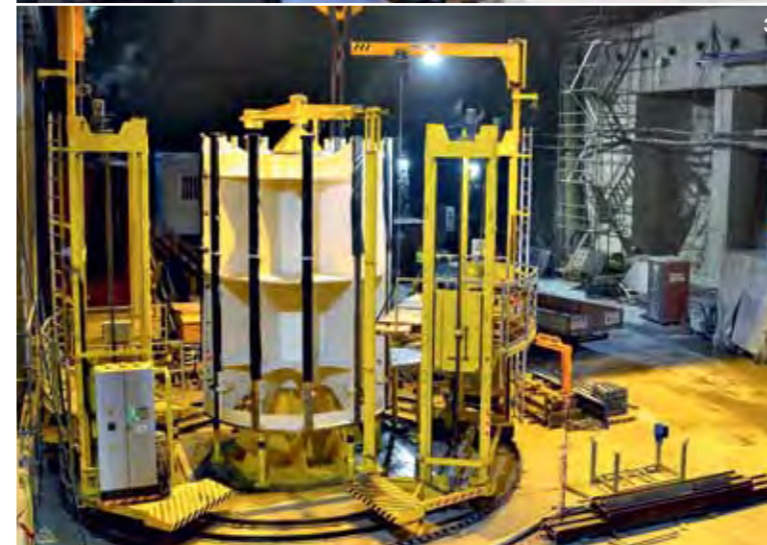

Flemming can prove: "In March 2016, we implemented a smart solution prototype based on an idea that was born just nine months earlier. That kind of implementation speed is unusual in the hydropower industry."

Last but not least, Flemming believes strongly that Voith's Industrie 4.0 "Smart Services" will only be credible if the company applies the same principles to its own operations. That's exactly what the other two pillars of Voith's Digital Solutions initiative, "Smart Factory" and "Smart Site," are all about. Within Voith factories, the team is, for example, increasing manufacturing efficiency through predictive maintenance concepts. Meanwhile, Smart Site initiatives are using digital technologies to improve logistics and communications between Voith factories and customer sites, to accelerate equipment delivery and plant completion times.

### A smarter future for hydropower

Speaking about the potential of Industrie 4.0 for Voith Hydro and its customers, Flemming concludes: "Hydropower is the perfect energy source for the 21st century because it's cheap, clean, and sustainable. Our digital solutions can help maximize its contribution to the energy mix by delivering cost and efficiency benefits that will be felt across the value chain, from plant manufacturers to hydropower operators and end users. Working with our customers to develop the solutions they actually need, when they need them, is the most effective and efficient way of delivering those benefits quickly. And our position as a trusted, long-term partner ensures customers have the confidence to invest with us in their future success." //



# MANAGEMENT INTERVIEW

On 1 January 2016, Uwe Wehnhardt became CEO of the Voith Hydro Management Board and his predecessor, Dr. Roland Münch, began leading the new Group Division, Voith Digital Solutions. **Here, both gentlemen discuss the future orientation and cooperation of the two organizations.**

**Dr. Münch, why has Voith established the Group Division, Voith Digital Solutions?**

As a result of ongoing digitalization, we have seen enormous changes over the last few years. Just think of the boom in online trading, or the development of smartphones and tablet PCs with their multiple functions. This digital transformation has now also reached industry. As a technological leader in many markets, we have a unique domain know-how, which we would like to utilize, in order to offer our customers optimum support with this transition into a new era. For this reason, we have pooled our automation and IT competencies within the new Group Division, Voith Digital Solutions. Together with our customers and partners, we would like to use this new division to jointly develop new digital applications.

**Mr. Wehnhardt, you have been a member of the Voith Hydro Management Board since 2011 and now you are its CEO. How do you see the future interaction between Voith Hydro and Voith Digital Solutions?**

Both divisions will cooperate very closely. Our customers will have the same contact persons in Hydro, there is no change – we work with the colleagues of the new division as one team and benefit from the fact that we are pooling and networking our core competencies from hydropower and automation. A hydropower plant is an extremely valuable asset, and for its operator it is ultimately a matter of his power plant running reliably 24 hours per day, 7 days a week and feeding power into the grid. With our new setup, we are able to focus on the development of solutions, in order to increase the availability of these plants, and thus also improve their economy.

**What do these new solutions look like?**

**Münch:** Due to constantly changing market requirements, hydropower plants have to be operated more and more



Uwe Wehnhardt, newly appointed CEO of Voith Hydro.

“Voith Hydro is excellently positioned. It is my sincerest intention and my responsibility to continue the successes of recent years and to add new ones.”

Uwe Wehnhardt,  
CEO, Voith Hydro

flexibly. This increases the demands on their technology. Consequently we have to provide new solutions for monitoring and controlling these plants more efficiently, in order to prevent downtime. For this we need optimum monitoring and diagnosis facilities. As a result, problems can be detected at an early stage and unscheduled downtime can be prevented more effectively through timely intervention.

**Wehnhardt:** And, if I may add Roland, we have already developed such systems. Today, new plants can be fitted with them as standard. And of course, we are also able to retrofit these devices into existing power plants.

**How do you handle the subject of safety in the Industrie 4.0 era?**

**Münch:** Safety has the highest priority! Our applications have to be as safe and secure as, for example, e-banking. The competencies for this have been available within the Voith Group for quite some time. With “Privacy and Security”, our IT has developed a product for Voith that we have been offering to other companies for some time now.

**Does this mean that Voith offers IT security in the market?**

**Münch:** Yes, exactly. We offer consultation, audits and software for IT security to other companies and have already successfully implemented several “Privacy and Security” projects.

**Will emerging markets and developing countries be isolated from the global economic development as a result of Industrie 4.0, or can the current developments be regarded as an opportunity for these countries?**

**Münch:** It is definitely an opportunity! Emerging markets in particular can benefit from it. There is often a lack of experts with years or decades of experience, the “old hands” who, when patrolling their power plant, can assess the condition of a plant just by listening to the noises it makes. This is where digital solutions can provide the answer. I am thinking, for example, of new apps that can be easily installed on a technician’s tablet PC. They enable him to record data and transfer it to a team >





Dr. Roland Münch, the new CEO of Voith Digital Solutions.

“Together with our customers and partners, we will jointly develop new digital applications, in order to strengthen the competitiveness of our customers.”

**Dr. Roland Münch,**  
CEO of Voith Digital Solutions

demand. As a result, we created training modules, first in Brazil and later in Canada, that are tailored to requirements in individual regions. These seminars have proven themselves to be a success and we intend to offer such training sessions on a global scale in future. For example, we have already started constructing a dedicated training center in West Africa.

**Mr. Wehnhardt, Voith Hydro is a highly successful company. In your capacity as the new CEO of Voith Hydro, how do you plan to continue this success story?**

Voith Hydro is indeed excellently positioned. It is my sincerest intention and my responsibility to continue the successes of recent years and to add new ones. Our employees play an important role in this. In my opinion, they are first class. Excellent employees lead to excellent achievements in the market and to high customer satisfaction. This is of maximum importance to me. With a view to our product portfolio, my chief concerns are the further expansion of small hydro and the continuous development of our global service network. In addition, through the development of innovations, Voith shall continue to occupy a top position among the leading engineering companies in global hydropower.

**Mr. Wehnhardt, we leave you with a personal question: what do you find most exciting about hydropower?**

There are many things that I find exciting. Above all, the fact that hydropower is a renewable, clean and reliable resource. Hydropower can store huge amounts of energy and thus support the expansion of renewable energies. Consequently, hydropower makes a significant contribution to reliable and eco-friendly energy supplies, and is the perfect basis for the sustainable and successful economic development of regions and societies. //

▷ of experts at Voith in real time. The team then analyzes the data and takes the relevant action. If required, service employees or spare parts can be sent to the power station immediately. This is just one example that demonstrates the huge opportunities that lie in these new digital applications.

**Talking about service: at which locations will the specialists from Voith Hydro and Voith Digital Solutions be based?**

**Wehnhardt:** Our company is globally positioned. This is something we won't change. Close proximity to our customers all over the world, and the ability to visit sites promptly with staff that are fluent in the local language, are two of our key strengths. Our customers will keep their established contacts.

**You have recently started to offer seminars for hydropower plant employees. Why does the plant engineer Voith supplement its portfolio with training offers?**

**Wehnhardt:** The idea actually originates from our customers, who approached us with their requests and we reacted to this

# COLLABORATION IS ALL

**A complex servicing requirement can't always be solved in isolation.** Voith Hydro teams in North America worked together to meet Canada's BC Hydro expectations for stay vane modification.

**In mid-2012, the Voith Hydro team in Canada** was awarded a project by BC Hydro to modernize the turbines for the GM Shrum Generating Station at the W.A.C Bennett Dam. The project involved the modification of the stay vane tips, which help turn pressure energy into kinetic energy, at the inlet and the outlet of the plant. Fulfilling the requirement to the highest possible standards

was Voith Hydro's first priority, which is why they called in expert assistance from their colleagues based in the United States. Over the following months, the teams from both countries traded knowledge and skills in installation, machining and hand grinding the hydraulic profiles of the stay vanes, ensuring the best possible result for the customer.

The GM Shrum project is a positive example of collaboration of Voith teams from different locations to complete a project with common goals. Existing technology information was shared between the teams to achieve the best solution. The result was a successful project for the customer and a newly trained workforce of machinists on the side of Voith for the North American market. //



International collaboration between Voith teams ensures maximum customer satisfaction.



# ALWAYS UP AND RUNNING

Voith HyService™ is committed to extending the life of hydropower plants and keeping them operating optimally, wherever they are.

“Our customers make huge investments in our technology when building a hydropower facility. Our mission is clear: to help them extract maximum value for the long term.” So says Kirsten Lange, Chief Business Development Officer of Voith Hydro with responsibility for the worldwide service business. Service is a huge undertaking, with challenges that range from working with technology that may be decades old, to accessing facilities in remote or dangerous locations. But the objectives are always clear – to keep equipment running smoothly, and to extend its functional life at any point in its life cycle.

With nearly 150 years of experience in manufacturing, installing and maintaining its own hydropower equipment, and looking after equipment from many other manufacturers, Voith is perfectly placed to achieve these objectives. And the advantages for customers are clear, as Lange explains: “As a full-line supplier, Voith offers a complete range of hydropower service solutions. Customers rely on us to minimize downtime. But it’s not just about repairing equipment when things

go wrong. We also focus on preventing future breakdowns and extending the life of equipment. After all, downtime costs our customers money, and by helping them reduce it, we make a positive impact on their bottom line.”

From simple repairs to general overhauls, restoring systems to their original state, or full maintenance contracts, Voith’s service capabilities cover all generator types, turbines and hydraulic machines and valves, as well as automation and auxiliary equipment. “It’s this breadth and depth of expertise that really sets Voith HyService apart,” says Christian Pötsch, Head of Service at Voith Hydro. “There is literally no problem we haven’t encountered, and our local service centers across the globe ensure knowledge is transferred easily, so that we can solve any issue quickly. It also ensures our high standards of service excellence are maintained everywhere, at all times. Moreover, we guarantee our services are delivered on time and on budget, for a wide range of hydropower equipment brands, not just our own.”



**Kirsten Lange**  
Chief Business Development Officer, Voith Hydro



**Christian Pötsch**  
Head of Service, Voith Hydro

## THE VOITH HYSERVICE™ PORTFOLIO

Voith HyService offers different products within these segments:



### ASSESSMENT AND CONSULTING

HyService’s Assessments and Consulting is based on experience and provides our customers with access to huge expertise in hydroelectric equipment. Our customers benefit from an early warning system and can define an individual framework to streamline, simplify and improve the hydroelectric equipment, thereby enhancing asset and risk management. This leads to significantly lower investment in replacing, repairing and refurbishing hydroelectric equipment, and less downtime.



### EDUCATION AND TRAINING

HyService’s Education and Training program is designed to meet a wide range of our customers’ needs, ranging from detailed technical courses for hydroelectric equipment engineers, to bird’s-eye view courses for commercial managers. For more details on the available courses, please contact our local Education and Training expert for customized information on the available course skills, certificates and schedules.  
North America: [noram.hydroschool@voith.com](mailto:noram.hydroschool@voith.com);  
Latin America: [latam.hydroschool@voith.com](mailto:latam.hydroschool@voith.com);  
Global: [hydroschool@voith.com](mailto:hydroschool@voith.com)



### MAINTENANCE

HyService’s Maintenance offers a wide range of services, from planning, monitoring and assistance, to continuous maintenance. Older machines need attention to maximize their operational lifetime. HyService experts can maintain all your hydroelectric equipment to ensure longevity and prevent unplanned outages. This includes scenarios such as the efficient restart of your unit after an outage. HyService also offers a one-stop solution with customized service contracts covering maintenance of all your hydroelectric equipment.



### SPARE PARTS

HyService’s Spare Parts deliver precision and reliability for customized spare parts. This guarantees the highest quality engineering, delivery and installation of original and customized spare parts for all our hydroelectric equipment. Our customers benefit from the fact that all machine components work perfectly together, and deliver maximum plant performance and longevity.



### REFURBISHMENT AND UPGRADES

HyService’s Refurbishment and Upgrades offering maintains the reliability of your hydroelectric equipment during its expected lifetime, and beyond. HyService experts deliver solutions to refurbish and upgrade all your hydroelectric equipment, restoring it to “as new” condition. This HyService increases your asset’s value, profitability and life expectancy, while simultaneously reducing operational and maintenance costs.



### REPAIR

HyService’s Repairs give our customers the confidence that if something goes wrong, any hydroelectric equipment affected by mechanical and electrical stresses can be repaired, even at very short notice. Our HyService experts can rely on experience to define the required scope of repair, and detect hidden failures.

Visit us at: [www.voith.com/hyservice](http://www.voith.com/hyservice)



# DEEP EXPERTISE

Voith Hydro Sarpsborg AS, based in Norway, **uses all its proven skills and experience** to meet customers' critical repair challenges.

won the competition to carry out this major rewinding project.

While the larger projects might capture the headlines, Voith Hydro Sarpsborg AS prides itself on the flexibility to take on a wide range of small commissions as well. This is exemplified by the work carried out at Eidsiva's Raula power plant, which was first put into operation in 1940. The winding on a 1.25 MVA generator needed to be replaced, and the customer had to decide between a repair, or an expensive, modern replacement. With a delivery time of around 12 to 13 months and a significant investment required for new equipment, they selected Voith Hydro's skilled handworkers to rewind the existing generator. The result? Instead of waiting more than a year to be back on line, the plant was up and running in eight months.

These projects support Torp's view that, when it comes to commissioning, customers choose Voith because of the company's deep knowledge and hard-won expertise. It is no surprise, therefore, when he repeatedly stresses that a strong focus on education and training underpins the success of the company. "We have been very eager to keep the technology in-house, and to take care of the legacy of the people who started the company," he says. "We know that this will enable us to serve our customers optimally. We have a long-term perspective and strategy for educating our staff and, with our workforce and unique skills, we will be able to meet our customers' needs, emergency or otherwise, for many years to come." //

**Voith Hydro Sarpsborg AS's portfolio** includes refurbishments, upgrades, repairs, and emergency repairs of generators and turbines at hydropower plants.

According to the company's marketing manager, Pål Heine Torp, the breadth of its high-quality generator services is at the heart of the portfolio, but there are certain aspects that really differentiate these services from competitive offerings. "What makes us special in generator refurbishments is that we have our own in-house winding production," explains Torp. "We produce what are called high-voltage generator windings with insulation that is impregnated with epoxy – and everything is done by hand. It's a methodology that we have perfected over many years." Moreover, it's one that can be critically important in rare emergencies, when an unexpected breakdown occurs.

A typical example of this kind of emergency repair was required recently at Akershus Energi's Funnefoss power plant, which has been operating successfully since 1975. The plant has two identical bulb units measuring 21.65 MVA and core plate fatigue caused a winding breakdown in one of the generators. Workers removed the damaged coils,

repaired the core plates and were given spares that dated back to the original delivery in 1975. "We took them to our winding lab for testing to make sure they were suitable for installation," says Torp. "Then the coils had to be cut in two and prepared for installation on site – a demanding task that requires extensive knowledge and experienced personnel." This allows the customer to sustain production for a few more years, until a more extensive investment can be made.

But it's not just historical expertise that sets the company apart in its ability to meet customer needs. In 2015, the company won a major contract with Norway's largest power producer, Statkraft. The project comprises the rewinding of three 62.5 MVA generators at the Øvre Røssåga power plant, opened in 1965. Running from 2015 to 2018, Torp describes it as a "real milestone in our history". This is not just due to the size of the contract, but because Statkraft have also created new technical specifications, the so-called Nordic Generator Technical Requirements. In order to win the contract, Voith had to demonstrate it could adhere to the new regulations and, after rigorous testing,



1



2



3

1&2 Repair works.  
3 Voith engineers examine a generator.



# TRAINING THE NEXT GENERATION

The Voith Hydro School is helping hydropower companies ensure a bright future for hydropower engineering.

- 1 Latin America's Voith Hydro School participants visit Voith's factory in São Paulo, Brazil.
- 2 Knowledge is passed on to young engineers.
- 3 Voith Hydro School participants in North America on workshop tour.

As more and more experienced engineers reach retirement age, it's vital for hydropower companies to retain as much specialist knowledge as possible. That is why, for example, Voith in North and South America offers its customer training service, Hydro School, enabling it to lead the way in educating the next generation.

In North America more than a third of the engineers now working for hydropower producers will have retired by 2017. The situation is similar in many other countries with long-established hydropower sectors. At the same time, the industry is facing ever growing demands to extend the operating life and increase the output of plants. That's why hydropower companies are now investing to ensure that valuable skills and knowledge are passed on to the next generation of engineers.

Voith is working closely with strategic partners to ensure employee education and training is as complete as pos-

sible and can give Voith customers a competitive advantage. With nearly 150 years of experience in hydropower and with its equipment installed in one out of every four hydropower units worldwide, Voith Hydro is ideally placed to play that partnership role. That's why the company has developed the Voith Hydro School: to harness the enormous amount of expert knowledge within the company, and share it to benefit hydropower operators worldwide.

"The hydropower market is always in need of trained and skilled professionals capable of dealing with the wide range of equipment and systems," explains Vanessa Romero, responsible for Voith's Hydro School in Latin America. "Our engineers enjoy interacting with our customers and hearing about issues and challenges they have come across in their own plants. The value of that dialogue is huge. It helps to set up the right training for almost all of our customers' needs," she says.

**"Sharing knowledge and expertise helps strengthen the relationship between Voith and its customers."**

**Cherie Ferrari,**  
Voith Hydro School

In North America, adult training expert Cherie Ferrari was recruited in October 2014 to develop courses for Voith customers. She agrees that Hydro School is as much about quality as it is about quantity, commenting, "Engineers like to hear from other engineers. Putting Voith experts in front of clients, telling their stories and sharing their knowledge and expertise is a great way for them to learn, and helps to strengthen the relationship between Voith and its customers."

Hydro School employs the principles of adult learning, using the internationally recognized Systematic Approach to Training (SAT) design methodology for course development. This puts strong emphasis on increasing on-the-job performance, with case studies and first-hand experience complementing the theory. The instructors are all Voith subject matter experts with deep knowledge and international experience in their fields. "The training that they themselves receive to become proficient trainers is a fundamental success factor," Cherie Ferrari points out.

As a result, the participants benefit, not just from well-taught theoretical knowledge, but also from sharing the practical experience of true industry experts. In this way, Hydro School helps hydropower companies avoid the risk of a "knowledge gap" that could otherwise emerge as experienced personnel retire.

tion, grid stability and energy mix. So far, several hundred people have been trained in classes of about 12 people each. Speaking about the popularity of the courses in Brazil, Vanessa Romero comments: "The feedback we've already received exceeds our expectations. Our customers are extremely satisfied with our courses and are now requesting new ones to cover other hydropower themes."

The two competence centers in the Americas are working closely together in the development of Hydro School, and demand is already spreading. In principle, Voith is able to offer its training and education program around the world. "We expect a strong demand from rapidly developing regions in the coming years, as local people will need to be trained to operate and maintain the growing number of hydropower plants to be installed there. We are prepared to meet specific customers' needs everywhere with our approach," says Christian Pötsch, Head of Service at Voith Hydro. "To this end, Hydro School is expanding its library of courses all the time. It is committed to obtaining the necessary certifications to meet professional accreditation requirements around the world, and so help customers master all their technical challenges." //

**For more information on Voith Hydro School, please contact:**  
North America: [noram.hydroschool@voith.com](mailto:noram.hydroschool@voith.com)  
Latin America: [latam.hydroschool@voith.com](mailto:latam.hydroschool@voith.com)  
Global: [hydroschool@voith.com](mailto:hydroschool@voith.com)



**Global and individual training**  
Voith offers over 20 individual courses covering topics as diverse as automation, speed regulation, voltage regula-





Kaplan turbine at the Voith Workshop in Heidenheim, Germany.

## MORE STABILITY, LESS WEAR

An innovative Voith software solution is helping extend the life of turbine components.

The growing use of renewable energy is affecting the stability of electrical grids worldwide. Volatile power sources such as solar and wind energy cause fluctuations in grid frequency, placing a greater strain on the conventional hydro or thermal power plants, which help stabilize the grid. Traditionally used only to compensate for variable consumer power demand, primary frequency control (PFC) mode operation is becoming increasingly important because of these fluctuations. In simple terms, PFC works like this: any deviation from the nominal grid frequency (50 Hz in Europe, or 60 Hz in the Americas and parts of Asia) results in a change of power output. If the grid frequency increases, the output must be reduced, and vice versa.

Applied to hydro turbines, this power output variability requires almost constant adjustment of the actuator by the turbine governor to regulate the flow of water through the wicket gate and into the turbine. This places increased stress on the bearings and reduces the lifetime of the mechanical parts. As Sven Brausewetter from Voith Hydro's R&D Automation team explains, PFC is particularly demanding for Kaplan and bulb turbines. "In addition to the wicket gate, adjusting the position of the runner blades acts as a second regulating device to optimize efficiency. However, due to mechanical restrictions, the control mechanisms are less wear-resistant than those for the wicket gate, and operating in PFC places them under con-

### Grid frequency management process for hydro turbines

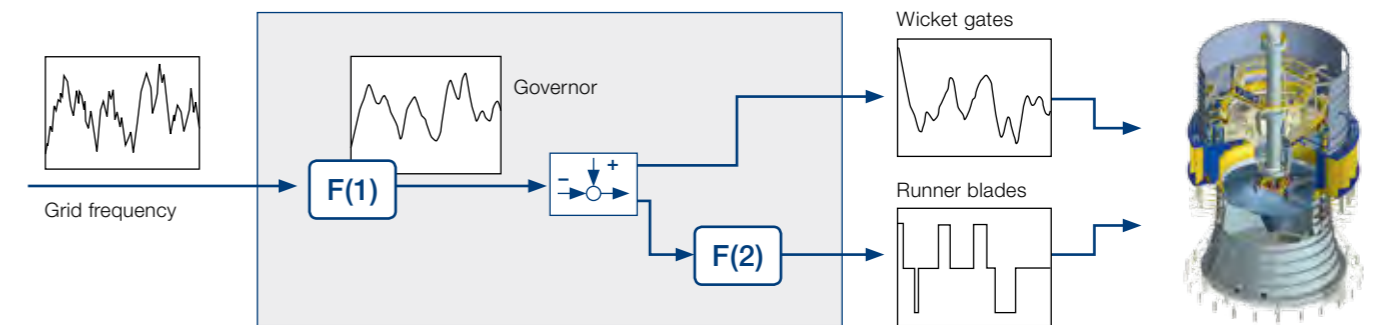

F(1) Intelligent non-linear filter for measurement of grid frequency.  
F(2) Quantization of runner blade setpoint.

siderable stress." This results in a conflict of interest between grid owners who want to optimize grid stability by using PFC on every power plant, and plant owners looking to maximize equipment longevity.

At Voith Hydro, Brausewetter and his colleagues have developed a two-part solution that significantly reduces the wear and tear on Kaplan and bulb turbines when operating in PFC mode. "The first part consists of a software module installed on the digital turbine governor that filters out small frequency changes," explains Brausewetter. "Grid frequencies change constantly, but the power output simply cannot change that fast. By applying this filter, we ensure smooth transitions between higher and lower output, which makes an effective contribution to grid stabilization, rather than more rapid, staccato jumps. The latter can, in extreme cases, even be counterproductive, because of the time delay caused by the unit."

The combination with the second software module is where the real innovation comes in, Brausewetter continues: "The relationship between the wicket gate and the runner blades is known as 'on-cam,' which means every time the wicket gate position changes, the runner blades are adjusted to achieve

optimum turbine efficiency. The problem is, the runner blades are more sensitive to continuous changes than the wicket gate. We developed a system that lets the wicket gate handle small changes to the power output without adjusting the runner blades. Although the turbine is no longer running at optimum efficiency, we have defined suitable parameters to ensure the efficiency loss is minimal."

Simulations and practical tests have shown a considerable reduction in the number of directional shifts for the wicket gate and runner blades: during PFC mode, runner blade movements are typically cut by a factor of more than 10, and wicket gate movements by a factor of between five and 10, reducing the stress on the mechanical

parts. Voith has already installed more than 15 units across Europe, including: three in hydropower plants in Uglich and Miatlinskaya belonging to Russian firm RusHydro; one at Budarhals hydroelectric plant in southern Iceland, which is owned and operated by Landsvirkjun; and three in hydropower plants along the Danube River at Abwinden-Asten, Ybbs-Persenbeug and Freudenu, all owned by Austrian VERBUND Hydro Power GmbH. "A major advantage of this solution is that it is 100% software-based and doesn't require any changes to the mechanical design of the power plant; it's an easy upgrade to make," says Brausewetter. "Increasingly volatile grids mean we expect to see a growing demand in the future." //

### WHAT IS PRIMARY FREQUENCY CONTROL MODE?

Primary frequency control mode operation maintains the balance between generation and demand in the power network using turbine speed governors. In the event of frequency deviation, this automatic decentralized function adjusts the generator output to ensure operational reliability in the seconds and minutes range. Primary frequency control mode is used to compensate for short-term fluctuations in consumer power demand, as well as exceptional cases like power plant or transmission line failure. Increasingly, it also compensates for the volatile fluctuations in energy production from renewable sources such as solar and wind energy.





1



2

1 Taking care of customer requirements  
2 Voith experts discussing a plant integration

## THE POWER OF INTEGRATION

Increasingly, **hydropower customers are demanding** complete plant solutions.

The market for hydropower plants has evolved significantly over the past 15 years. But changing customer requirements and further rapid advances in technology promise an even more radical transformation over the next decade.

Large energy suppliers usually operate a variety of power plants, from hydro to thermal, wind or solar plants. That means they are less likely to have the depth and breadth of engineering resources in house for each plant variety as they would have done in the past. Today plant owners want to shorten the time between hydropower investment money going out, and electricity sales revenue coming in.

“Many of our customers want to generate energy without having to deal with engineering, interfaces, integration of turbines, generators, balance of plant, governors or automation. They expect us to deliver a complete hydropower plant,” explains Dr. Manuel Gonçalves, Voith Hydro’s Chief Engineer in Brazil.

And Voith is best positioned to meet their needs. “Over the last few years, we have developed a team of plant engineers, mostly with backgrounds in automation, plant operation, or plant construction,” says Dr. Manuel Gonçalves. “But we also have the technical engineering know-how, acquired over many generations, to support our approach to plant integration. This enables us to deliver a fully integrated turnkey plant unique in the marketplace.”

Voith takes a very customer-centric approach to plant delivery. As soon as a contract is signed, a “plant engineer” is assigned as the single point of contact within Voith for every aspect of the new plant’s life – from initial financing, which might include arranging loans and credits from the World Bank, for example, right through to commissioning. And now, Voith is also beginning to build in comprehensive data monitoring, reporting and analysis capabilities to help ensure the reliability of plant processes.

“This is Industrie 4.0 in action, and it’s these kind of innovations that ensure customers’ integrated plant investments will pay off for years to come,” concludes Dr. Gonçalves. //



1

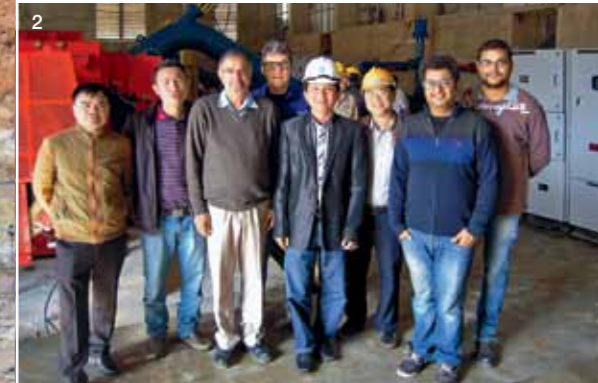

1 Dakter I powerhouse construction site in the Vietnamese mountains.  
2 The Dakter commissioning team.

## LESS IS MORE

Standardization at the Dakter power plant in Vietnam means **less complexity and easier operation.**

The planning and installation of the Dakter hydropower plant in Vietnam began in the same way as many other projects. However, by the time the plant was up and running, it had become something of a model for high-tech, standardized installations.

The project involved the installation of two hydroelectric power plants in a mountainous region between the largest city in the country, Saigon (officially, Ho Chi Minh City), and the capital, Hanoi. Phu Thinh Kon Tum Joint Stock Company commissioned Voith to create the power plants and the work was carried out between 2013 and 2015.

Dakter I is located upstream in the mountains. The powerhouse produces 4 MW using two machine sets, each with a 2 MW Pelton turbine. Dakter II is

further downstream and also produces 4 MW, utilizing the remaining head with two Francis turbines.

Voith delivered full electromechanical equipment for the project, ranging from the power unit, to balance-of-plant (BoP) mechanical and electrical systems, as well as the complete unit and plant automation. Uniquely, the customer’s late request for complete provisioning and installation allowed Voith to apply core parts from the new Small Hydro (SH) Plant & Control Standard.

The BoP systems were built from functional modules, which include all the technical aspects, such as hydraulics, electric, process data, control and visualization. Patric Sailer, Voith Manager of SH Generator and Automation, stressed, “It’s a change from engineer-

ing in disciplines (hydraulic, then electrical, then control) to integrated engineering based on standard, pre-tested templates. So, with the selection of, for example, a pneumatic governor unit, the electricity supply for the pumps, as well as the control and visualization of the system, is also defined. This allows the plant to be defined early, which reduces lead time and increases process stability in execution.”

Besides the modular approach, there was a focus on keeping complexity low within the standard, by utilizing a lower variance and more multifunction components. This translates into a relatively low investment, as well as simplified maintenance and training for the operators.

Importantly, the use of standardized, high-quality components – and fewer of them – reduces failure probabilities, makes problem-solving easier, and requires a smaller stock of spare parts. “This allows us to eliminate elements in the system that aren’t really necessary,” says Sailer. “The reduced complexity is very important – in fact, Dakter exemplifies the fact that sometimes, less is more.” //



# MILESTONES IN TURBINE GOVERNOR DEVELOPMENTS

Voith has driven innovation in turbine control technology since the late 19th century.

A milestone in the history of energy generation from hydropower was reached with the invention of the turbine governor, as efficient electricity production is only possible if turbine and generator speeds are precisely adjusted. Voith is one of the pioneers of turbine governor development. As early as 1891, the company launched the “Pfarr Governor” onto the market. Two years later, this innovation was registered at the Imperial Patent Office in Berlin as Patent No. 69179. The 20th century saw the company make numerous improvements and introduce new developments, forming the basis for the modern automation technology of the 21st century.

## 1891

Voith engineer Adolf Pfarr designs the Pfarr Governor, an innovative mechanical device with a centrifugal pendulum for measuring the speed of the turbine. In the same year, a turbine equipped with a Voith speed governor developed by Pfarr made the first transmission of electric energy from Lauffen on the Neckar to Frankfurt/Main possible.

Adolf Pfarr joined Voith in 1875 and became a director of the company in 1893. The engineer contributed significantly to solving the problems of governing and acceptance testing of hydraulic turbines.

## 1903

Another Voith engineer, Carlos Schmitthenner, developed the company’s first hydraulic governor, making further significant improvements to the design in 1905, 1909 and 1914.

## 1928

Another first for Voith: the development of a universal governor that could be used to control all turbine sizes and types. Contained within its own housing, the “Governor with Inter-

locking Unit” was a small centrifugal pendulum, linked to several servomotors.

## 1952

Voith developed its first electro-hydraulic governor for speed control and power control of hydropower units called “System Voith-BBC.” The control unit of the electro-hydraulic speed controller consisted of a frequency meter (BBC) combined with a mechanical-hydraulic stabilizing device (Voith). The frequency meter replaced the former centrifugal pendulum.

## 1960

Voith’s 10,000th turbine governor was delivered to the hydropower plant at the Danube River in Oberelchingen near Ulm, Germany.

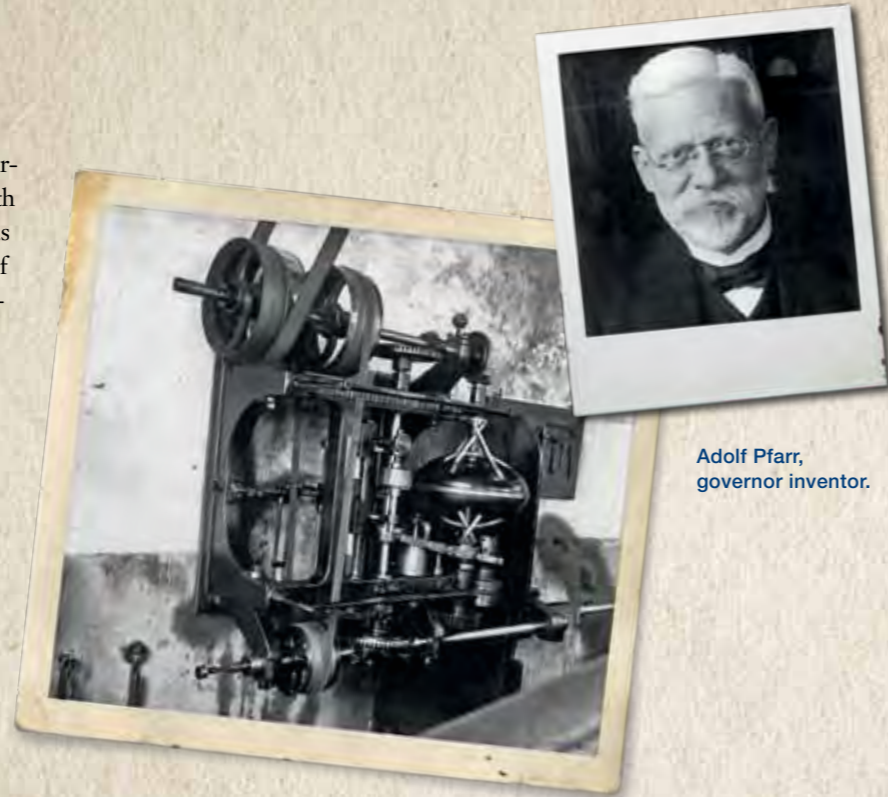

Pfarr Governor in operation at Königsbronn, Germany.



Adolf Pfarr, governor inventor.



1893 – Patent No. 69179 for the Pfarr Governor is granted.



1891 – the newly developed Pfarr Governor.

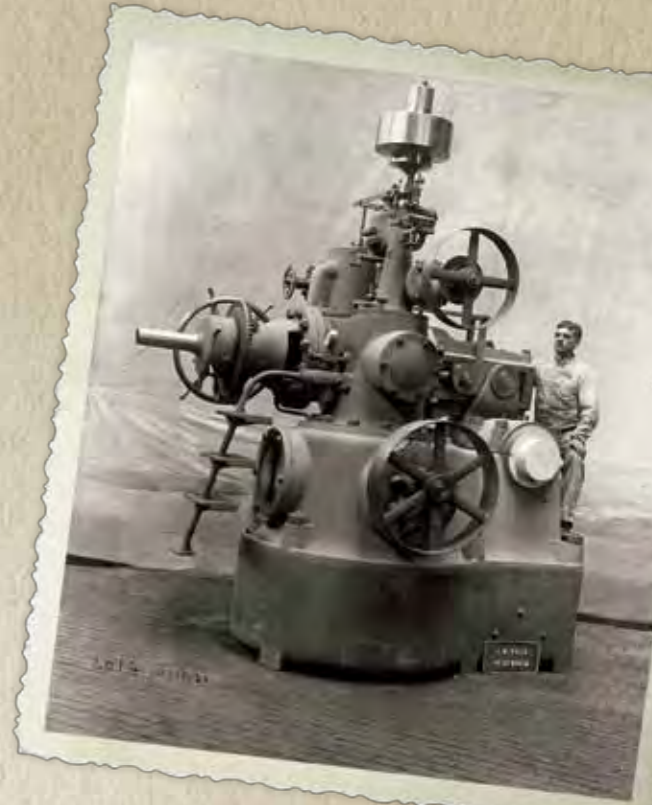

1909 – Hydraulic governor for Meitingen Germany.

## 1960s

Voith develops a servo valve as a connecting element between the electric governor and hydraulic amplifying equipment. The moving coil type servo valve facilitates the conversion of an electric input signal into a hydraulic or mechanical output signal. The “Voith Moving Coil” is still on the market.

## 1968

Voith engineer Kurt Hasenmaier developed the first electro-hydraulic governor (EHR 68) and later a corresponding double governor (EHR 68 D). Both were particularly suited to smaller, automatically controlled hydropower plants.

## 1974 and 1978

Further innovation in the era of analog electronic governors brought the development of Voith’s EHR 74 and EHR 78 governor systems. Both were installed many times and some of them are still in operation.

## 1985 and 1986

Voith was again in the vanguard of developing an innovative generation of governors with the introduction of the first digital governor. This was followed by the launch of the Voith Control Center VCC, which included turbine control functions, sequences and control of auxiliaries, as well as a high-precision turbine governor. The hardware was now based on industrially proven, commercially and globally available, standard Programmable Logic Controllers (PLCs).



1960s – Voith Moving Coil and additional control equipment.

## Outlook

Three decades ago, almost 100 years after Adolf Pfarr’s original invention, Voith wrote a new chapter in its technological history with the launch of its digital governor. Since then, Voith’s engineers have continuously developed the company’s automation and control technologies, beginning the millennium with the introduction of the HyCon product family, and following this up with today’s trend-defining solutions for the new Industrie 4.0 era.





Herdecke, Germany



Newfoundland, Canada

# AUTOMATION IN ACTION

Voith has **successfully automated** many hydropower plants in every corner of the globe.



## HERDECKE

Installed capacity: **153 MW**

Voith delivered a complete control system and replaced the generator poles as part of the modernization of the Herdecke plant in Germany in 2007.

Voith supplies tailor-made components and system solutions that automate hydropower plant operation to ensure reliable energy production. Hydropower producers benefit from predictable operation and enhanced profitability, while their customers get a dependable, clean source of energy. Here are just a few examples of Voith automation systems in action.

### Germany

In 2007 the pumped storage power plant in Herdecke, Germany, was modernized,

and Voith delivered the entire control system, including the turbine governor, and replaced the generator poles. The plant is a very important peak load power plant, and its availability and functionality are top priorities. That is why the HyCon 400 system, which was specially developed for the requirements of large hydropower plants and particularly of pump turbines, was selected for the project. The real highlight: the service engineers at Voith can support and consult with RWE Power from Heidenheim via specially secured remote access.

### Indonesia

The Rajamandala hydropower plant is a run-of-river site that will have a capacity of 46.6 MW. It is located in the Rajamandala on Citarum Basin, in the Cianjur Regency, West Java Province, Indonesia. Voith Fuji is supplying extensive automation systems for the plant including a digital turbine governor, turbine control panel and excitation system for reliable, maintenance-free control of the stator voltage and reactive power.

### Canada

The Churchill Falls power plant in Newfoundland, Canada, is a cavern plant with 11 Francis turbines generating 500 MW each, deployed more than 300 m underground. Originally commissioned in 1971, after more than 40 years of operation, the plant's automated control systems had become obsolete. In 2015, Voith began modernizing the unit controls and unit protection, upgrading the governor, and replacing the excita-



**RAJAMANDALA**

Installed capacity: **46.6 MW**

Voith Fuji is supplying extensive automation systems for the Rajamandala hydropower plant in Indonesia.



**CHURCHILL FALLS**

Installed capacity: **5,500 MW**

In 2015, Voith began modernizing the 40-year-old automation systems installed at the Churchill Falls hydropower plant in Canada.



**JUQUIÁ**

Installed capacity, Serraria: **24 MW**

Installed capacity, Iporanga: **36.9 MW**

In 2012, Voith was contracted to supply automation equipment to the Serraria and Iporanga hydropower plants in Brazil.

tion and intake gate controls with modern programmable components.

### Brazil

In 2012, Voith was awarded contracts to modernize the Serraria and Iporanga hydropower plants located in the municipality of Juquiá, around 90 km from São Paulo. From an automation perspective, the scope of supply included HyCon control systems, a digital governor and an excitation system, among





Omkareshwar, India



Budarhals, Iceland



**OMKARESHWAR**

Installed capacity: 520 MW

The Omkareshwar plant in India features eight Voith Francis turbines, eight generators and a complete automation system from the Voith HyCon product family.



**BUDARHALS**

Installed capacity: 95 MW

The new Budarhals hydropower facility in Iceland has been fitted with a Voith Hydro HyCon 400 control system.



**GILGEL GIBE II**

Installed capacity: 420 MW

Ethiopia's second-largest hydropower facility is equipped with turbines, generators and a complete set of mechanical and electrical equipment, including a HyCon 400 control system.



Gilgel Gibe II, Ethiopia



Kargi, Turkey



**KARGI**

Installed capacity: 102 MW

Officially opened in August 2015, the Kargi hydropower plant in Turkey features a complete set of Voith electromechanical equipment, including a HyCon 300 control system.

other elements. Implemented in 2014, these modernization projects have enabled owner-operator Votorantim to run the Juquiá complex remotely, lower system failure rates and lower the time to diagnose problems. Voith's ability to supply complete systems with a dedicated automation lab for testing was a decisive factor in its favor.

**India**

In November 2007, the Omkareshwar hydropower plant was connected to the grid with an installed capacity of 520 MW. Voith had delivered eight Francis turbines, each with synchronous generators, including excitation unit, control and monitoring systems, generator bus ducts, and auxiliary systems. Each unit has a total capacity of 65 MW. In addition, a complete automation system from the HyCon product family had been installed.

**Iceland**

In spring 2014, the Budarhals hydropower plant in Iceland was inaugurated. Voith supplied and installed two Kaplan turbines with a modern environmentally friendly design and water-filled runner hubs, as well as generators with state-

of-the-art technology using brushless thyristor controlled exciters, and the HyCon 400 control system. The Budarhals hydropower plant will run with an installed capacity of 95 MW and an estimated annual energy generating capacity of 585 GWh.

**Ethiopia**

Gilgel Gibe II is currently Ethiopia's second-largest hydroelectric plant, with an installed capacity of 420 MW. By supplying four Pelton turbines and generators, as well as the entire mechanical and electrical equipment, including a HyCon 400 control system, Voith has helped raise Ethiopia's hydro capacity by over 50%. The automated turbine-generator units will be transforming water energy into electricity for many decades to come, with no fuel cost – a crucial factor for sustaining economic progress in Ethiopia.

**Turkey**

The Kargi hydropower plant, with an installed capacity of 102 MW, is located on the Kizilirmak River in the districts of Osmancik and Kargi in northern Turkey. After four years of construction, Kargi began commercial operation in May 2015, and was officially opened in August 2015. Voith supplied the complete electromechanical equipment set for the plant, including the HyCon Thyristor Excitation System, as part of a turnkey installation that now powers 150,000 Turkish homes. //





**Debbie Myers** works in the service team at Voith Hydro in York, Pennsylvania, USA. She joined the company in 1987, initially working in administration for field operations, before establishing herself as a service specialist for customers across North America.



**Raj Vidyarthi** is Vice President Service at Voith Hydro Noida, just outside New Delhi in northern India. After working as an electrical engineer at thermal and gas power plants, he completed an MBA and joined Voith in 2009. Vidyarthi has built up a team of nine experts from scratch, carrying out a full range of service activities across India and southeast Asia.

# SERVICE HEROES

**Two hydropower service experts, on different continents and with very different roles and experiences, explain what makes their jobs so special to them.**

**You have had a slightly unusual career path – how did you get from administration to service specialist?**

**Debbie Myers:** I started off assisting the engineers with proposals. The more I did it, the more I wanted to learn. I got to know the internal processes and familiarized myself with engineering functions, especially learning to read and find associated drawings. After a while, I started handling spare parts requests and creating my own customer proposals.

**Was it a big challenge without a technical background?**

For me, that was the big appeal – the challenge of learning. I also knew that I could ask for help from our engineering team. I support them and they support me. Of course, there would be an oversight now and then, but that is how you learn.

**How would you describe your role now?**

It's like I run my own parts business. I perform most of the spare parts process, which is a bit unusual, but it works for me. I find I get a quicker response to the customer that way. I could never have imagined when I started that I'd be handling all the things that I do now: I deal with requests, proposals and maintain a project management role, following up to make sure things get done on time. That also includes the shipping, tracking and invoicing. I want to make sure everything is perfect and complete, and the customer is satisfied.

**After almost 30 years, you must be a useful source of information for your colleagues?**

People come to me asking where to find old drawings, archived data, order histories – you name it. The same goes for customer insight: I've worked with some of our clients for a very long time and have a lot of good relationships with them.

**What has changed during that time?**

The main thing is that market requirements and people change. This is a people-oriented job and I want to make sure that every customer is happy whatever the size of the order – every single one is important. That's Voith "HyService."

**What were the main challenges in setting up Voith Hydro's dedicated service team in India?**

**Raj Vidyarthi:** Voith India was incorporated in 2002, so we mostly serviced equipment that was provided by other Voith operating units. We cooperated with colleagues at other Voith locations around the world to ensure we had all the required information and expertise. A large proportion of the Voith equipment installed in India came from Voith Fuji in Japan, so we have worked closely with them to develop our expertise.

**What sort of services are you now able to offer?**

We service the full product spectrum: from hydroturbines to generators and automation equipment. This includes spare parts, assessments, maintenance, repairs, refurbishment and upgrades. To give customers maximum return on their investment, we focus on preventive and predictive maintenance, and improving reliability. This enhances equipment lifetime, minimizes costly downtime, and improves profitability.

**Can you describe some of the projects you are currently working on?**

Our current projects include: the design, manufacturing and replacement of a 200 MVA generator stator; the overhaul and refurbishment of a Kaplan turbine generator; the replacement of six large Francis turbine runners for a plant in northern India; and the upgrade of two governors for a plant in western India. We have also recently completed a two-year maintenance contract at a 450 MW plant, where two engineers worked on site to provide daily support for the

entire period. This contract has now been extended for another two years.

**Is demand for service in the Indian market growing?**

Definitely. For financial and political reasons, the construction of new hydropower plants has slowed, so the focus is shifting to improving those already in operation. And the demands placed on these hydropower plants are rising as they are required to bring valuable stability to the grid.

**What sort of challenges does the Indian market present?**

As well as central government utility companies, each state also has its own, which brings a variety of process requirements for service providers. Many of the states have separate languages and cultural norms that we have to consider, while the sheer size of the country can be challenging. But we are managing well, and we have extended responsibility for projects in Thailand, the Philippines, Indonesia and Vietnam. We've set up small offices in Vietnam and Indonesia to be closer to our customers and we are already passing on what we have learned to our new colleagues.

**How do you measure success?**

Our business is a long-term one. We are not just there for one or two jobs, we are there for the complete life cycle of a plant. So, success for me is about building a long-term relationship with a customer. It's also heartening to see the difference our work makes, helping our customers to bring electricity, development and prosperity to many people. //



# COMPREHENSIVE COMPETENCE

**Voith understands its customers' needs are diverse.** The breadth and depth of its full-line expertise, supported by multiple acquisitions and joint ventures, ensure every requirement can be met.

Over almost 150 years, Voith has become much more than a manufacturer of first-class technical hydropower equipment. As a world leader in hydropower solutions, its engineers complete, turnkey power plants. The company has developed these capabilities through organic growth, acquisitions and joint ventures (see table page 39). As a result, the scope of Voith's portfolio includes: generators, turbines, automation solutions and auxiliary systems; the construction of new plants and the modernization of existing ones; and a full range of maintenance, repair and consultancy services. But at every stage in this exciting journey, one element has remained constant: foresight that helps meet the energy challenges of the future.

Friedrich Voith launched his first commercial turbine in 1870. Just 33 years later, the company he built cemented its reputation as a world leader in hydropower technology by manufac-

turing and installing the largest and most powerful turbines of the time for Ontario Power at Niagara Falls, Canada, in 1903. That legacy has been built upon through the Brunnenmühle research facility at the company's headquarters in Heidenheim. Over the last century, it has established itself globally as a center of excellence for the development of hydropower technology. But Voith's exceptional competence is not just about engineering.

Ensuring projects are completed on time and on budget is only possible through the optimal cooperation of all the relevant stakeholders. That's why Voith offers complete turnkey solutions for its customers. This involves the supply of concepts, customized design, production, quality control and project management, through to ongoing maintenance, spare parts delivery, repair and operational optimization. In other words, Voith covers the entire life cycle and all the relevant components of ▷

Testing and quality control  
ensure maximum reliability.





Voith engineers ensure the highest levels of product quality for customers globally.



▷ hydropower plants, both large and small. Decades of experience, combined with the expertise of project managers, enable the best solution to be identified every time, even for specialized requirements. As a result, Voith's customers benefit from fully integrated solutions from a single source – anywhere in the world. Voith's acquisition of and joint ventures with many leading hydropower technology companies over the years directly support this capability, because it means the company's competence extends across a wide range of OEM technologies.

Importantly, reliability and efficiency are always key objectives of every Voith hydropower project, no matter what the mix of components being used within the project, and regardless of the size of the plant. Small plants are often built to guarantee a stable, localized and renewable energy supply. The largest and most powerful hydroelectric plants in the world, many of which use Voith's technologies, are the most efficient way of generating reliable, renewable power for millions of people. Voith's expertise is key to ensuring these plants operate optimally for power generators and their customers.

The focus on reliability also extends to the service environment, where Voith excels as the premier specialist in field

machining, cavitation repair and outage services. From replace-in-kind to optimized repair, full rehabilitation or part replacement, Voith ensures customers' systems are up and running as quickly as possible, even if that involves designing customized solutions. Minimizing costs and outage times are always the top priorities.

Looking ahead, there are two constants that will define Voith Hydro's work in the future: the increasing global demand for clean and reliable electricity, and the need for reliable suppliers

like Voith that have the capability and skills to manage complex plants, or service existing ones. That's why the company's excellence in process management is so important. More than 20 engineering and manufacturing units, working with a diverse range of Voith and OEM technologies, give customers the peace of mind that no matter where or how they work with Voith Hydro, or which technologies they use, quality will remain optimal in every area of the plant, across every project phase. Comprehensive competence indeed. //

OEM acquisition and joint venture timeline

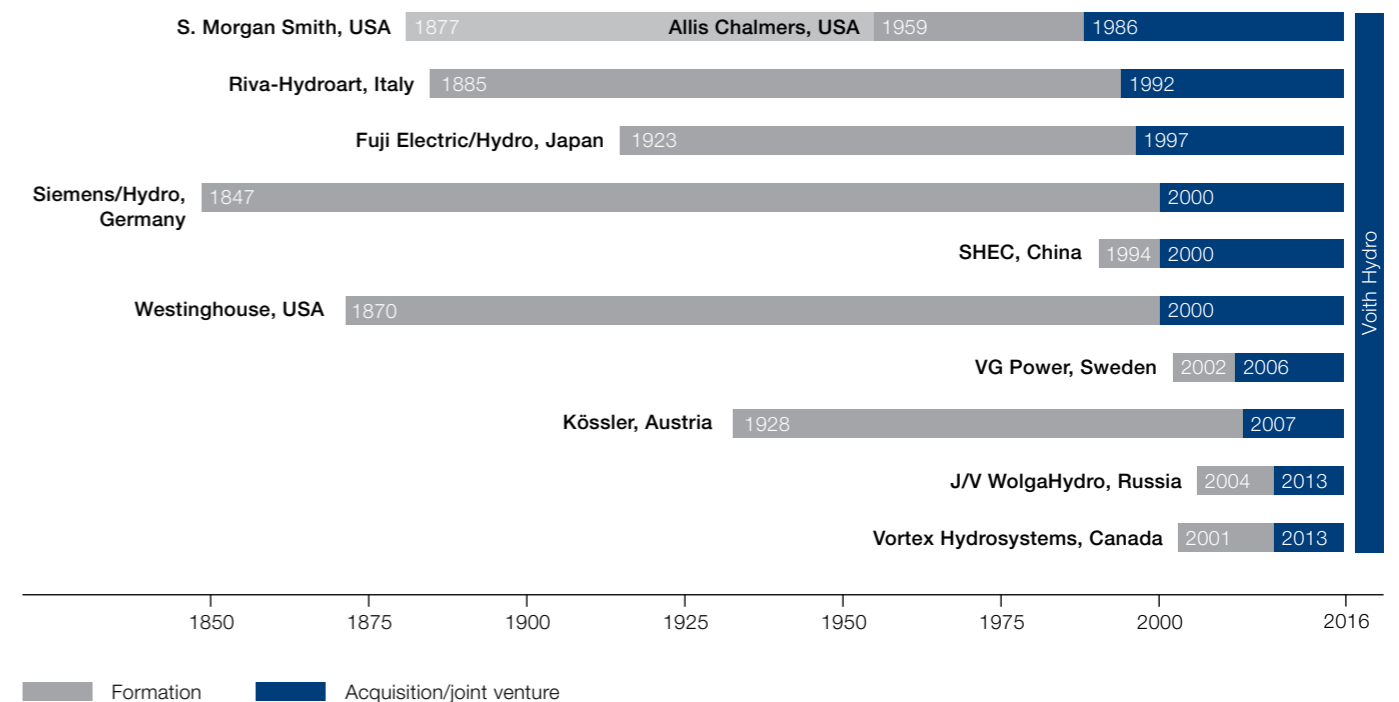





## NATURAL POWER

**Salal Hydroelectric Plant** is located on the Chenab River in northern India. In 2014, Voith was awarded a contract to supply and install six new Francis turbine runners. The runners are manufactured at Voith Hydro's workshop in Vadodara, India and will be gradually delivered to reconnect the units to the grid, step by step.

### #HYDROPICTUREOFTHWEEK

Scan the QR code below or visit [twitter.com/Voith\\_Hydro](https://twitter.com/Voith_Hydro) to keep up with Voith Hydro news.

Be sure to check out our feed every Friday when we share our hydropower picture of the week!







Narrow gap welding at the Voith Hydro workshop in Shanghai.

## MIND THE GAP

Voith innovations in narrow gap welding for shorter manufacturing lead times and improved quality.

Traditionally, thick steel plates – such as turbine deck plates, for example – are fused together by manual gas metal arc welding (GMAW), or flux-cored arc welding (FCAW). This achieves the high quality standards required for joining steel plates up to 240 mm thick. These processes also use a large volume of filler material, require highly skilled and experienced welders to achieve the quality expected, and are time consuming. Voith asked its welding specialists to identify ways of improving welding efficiency and quality. The solution developed by Voith engineers in Austria and China is robot-assisted narrow gap welding (NGW).

Typically used in the manufacture of very large offshore wind turbines – as well as by the oil and gas industries for

joining large pipes – NGW's narrower weld seam width requires 35% less filler metal than traditional welding processes. However, it is only possible to undertake NGW on thicker pieces of metal using robotics.

The team at Voith Hydro's St. Pölten plant in Austria began work on the project in October 2014. Equipment was installed in July 2015 and testing commenced two months later. The method soon found its way into commercial use. The tungsten inert gas (TIG) welding system the team has developed is capable of joining steel plates up to 200 mm thick. Until recently, TIG had only been used for the precise small welds needed for critical joints.

According to the project leader in Austria, Martin Rohrer, "The plan from

day one was to look at all the parts we make here for which this technology might be suitable in the future, including runners. The system saves time and uses less welding material." The main benefit of employing this method is the shorter lead times in manufacturing. The TIG system is also versatile, in that it can weld pieces in overhead and upright positions, as well as on the flat.

Meanwhile, the Voith team in Shanghai, China, has also developed its own NGW robotic welding system. This argon/CO<sub>2</sub> GMAW system welds plates up to 240 mm thick. It is currently being used to make deck plates for the stay rings, head covers and bottom rings of turbines for the 850 MW Wudongde hydro project on the Jinsha River.

The head of the welding project in Shanghai, Feng Jiang, says the benefits of this approach are significant in terms of welding time, along with consistent and optimal weld quality. As usual, Voith's R&D department in Germany is keeping a close eye on both projects, with a view to sharing the new technologies with other manufacturing plants throughout the group. //

# WORLD OF VOITH

The latest news from **across the divisions** of the Voith Group.



## HEAVY LIFTING

VOITH INDUSTRIAL SERVICES faced a tight deadline for the turnaround activities at Raffinerie Heide GmbH in northern Germany in September 2015. That's why a precise plan covering every task to be performed by each of the 200-strong team in 10 days was the key to success. These tasks included the overhaul of 75 heat exchangers and 60 containers, as well as air coolers and columns, extensive furnace modifications, and the replacement of a Packinox heat exchanger weighing 74 metric tons. The limited space for the big cranes as well as the transport of large-scale equipment and the Packinox within the plant proved to be particularly tough. But the Voith Industrial Services team delivered: 25,000 accident-free working hours and one very satisfied customer.

## MAKING HISTORY

VOITH TURBO is collaborating with the Changchun Railway Vehicles Company Ltd. (CRC) to introduce China's first ever hybrid-powered railway vehicles for commuter, regional, national and intercity rail services. Using tried and tested technology, Voith's RailPack 400DE hybrid drive system for diesel-electric railway cars is designed to be used in diesel mode on rail routes that have not yet been fully electrified, and in zero-emission electric mode on electrified sections. Crucially, the RailPack 400DE meets all CRC's specific requirements, including a top speed of 120km/h, a quick-switch system between diesel and electric modes, and the ability to withstand extreme climatic conditions, in regions where temperatures can drop to -40°C.



## PEAK PRODUCTION

VOITH PAPER is celebrating an order from Segezha Pulp and Paper Mill (PPM) to supply a complete process line for sack-paper production. The new PM 11 machine has an annual capacity of 110,000 metric tons, which will allow Segezha PPM to increase site production by 40%. It's a key element in achieving the company's goal of becoming the world's second-largest producer of sack paper, and according to Segezha Group President Sergey Pomelov, the outlook is very positive: "We are confident we can achieve this goal in collaboration with Voith."



# WORKING OUT WATER SHORTAGE

Hydrogeologist Dr. Tom Gleeson helps us to understand how sustainable the planet's groundwater reserves really are.



Dr. Tom Gleeson is an Assistant Professor at the University of Victoria in Western Canada, who combines an unusually broad range of scientific disciplines to research groundwater sustainability, groundwater-surface water interactions and fluid flow around geologic structures.

There's no doubt about it: water shortage is one of the biggest challenges facing humanity in the 21st century. Non-profit organization The Water Project, which helps communities in sub-Saharan Africa access clean water and sanitation, estimates that nearly 1 billion people, or more than 10% of the world's population, don't have access to a safe water supply. The word 'safe' here is important, because in its broadest sense, water scarcity can be about quantity (physical shortage), or quality (economic scarcity). But either way, the reality is that water scarcity is a threat.

Moreover, water is a finite resource, and most of it is either salt water, frozen in ice, or stored underground. In fact, the Environmental Protection Agency in the USA estimates that only 1% of all the water on the planet is readily available for human use. In this context, investigating that 1% more closely is of great social and economic importance – especially

when it comes to water supplies that you can't actually see.

### The world's invisible water supply

Dr. Tom Gleeson is a hydrogeologist on a mission: to work out not just how much groundwater there is – there have been good estimates of that available since the 1970s – but how sustainable it is for the future. Together with an international team of researchers, Dr. Gleeson spent two years studying the extent and sustainability of global groundwater, before publishing the findings in the *Nature Geoscience* journal in November 2015.

"Broadly speaking, groundwater can be divided into three categories – young, modern and old. We define young groundwater as that which is less than 100 years old, and modern as that which has been replenished within the last 50 years. These reserves usually lie within 200 meters of the earth's



2

- 1 Exploring groundwater-fed water sources.
- 2 Climate change can affect groundwater quality.

"I hope that governments and NGOs will be able to use our data to identify which modern groundwater reserves need to be protected."

Dr. Tom Gleeson,  
Assistant Professor, University of Victoria

surface. Old groundwater can be centuries old and can lie kilometers deep. However, it's difficult to access, is sometimes not easily replenished, and can be unusable because of a high metal or salt content."

### Innovative methodologies, interesting results

Gleeson prefers to combine an unusually broad range of methodologies in his research, from field studies and numerical modeling, to environmental chemistry and policy studies. For this study, entitled, "The global volume and distribution of modern groundwater", a com-

bination of computer simulations, large sets of geological data, and measuring the presence of tritium, a radioactive isotope of hydrogen, to determine the age of water sources, were used.

He explains, "The study was a collaborative effort between myself at the University of Victoria, and colleagues from the University of Calgary, the University of Texas in Austin, and Georg-August-University in Göttingen, Germany. At the end of the two years, we discovered that although the total volume of modern groundwater is three times larger than all the fresh, non-frozen water on the earth's surface, it rep-

resents just 6% of the total groundwater in the earth's crust. Moreover, although it is more accessible and usually more suitable for human consumption than old groundwater, its proximity to the surface makes it a lot more sensitive to contamination from industry and the effects of climate change."

In certain parts of the world, this valuable resource is already being degraded. "We know that in some regions, such as the Western USA, and parts of China and India, groundwater is being used in a non-renewable way. At the moment we can't accurately estimate how much of that water can be replenished because it depends on so many local factors, such as precipitation and proximity to surface water sources such as rivers and lakes."

And here is the dilemma: on one hand, there is a huge demand for water everywhere, especially in regions where clean surface water is scarce. On the other, if those regions can potentially access a usable reserve of modern groundwater, they may be depleting or contaminating a resource.

Although groundwater research can't solve this problem on its own, Dr. Gleeson is hopeful that it will make a valuable contribution to the debate. "I hope that governments and NGOs will be able to use our data to identify, for example, which modern groundwater reserves need to be protected because they are most at risk of contamination." //





# FIVE QUESTIONS FOR ...

**Martin Andrä,**  
new Executive Vice President and globally responsible Chief Marketing Officer of Voith Hydro.

**1 Mr. Andrä, what are your goals as the new global CMO for Voith Hydro?**

My primary aim is to focus and align our strengths in hydropower in every region, so our customers benefit from our best performance. Regardless of project type or scope, we want to satisfy the needs of our customers optimally, all over the world. Moreover, we want to do this from the beginning of a project, through to commissioning, followed by our services.

**2 You have been with Voith for over 15 years. Why?**

Because I really appreciate Voith's corporate culture. At Voith, you are given responsibility and the freedom to think creatively and develop. These are important preconditions for great commitment and dedication. Putting the customer first, which always guides my thoughts and actions, is extremely important here at Voith, in order to secure the trust of our global customers.

**3 What makes you enthusiastic about hydropower?**

I decided to work in energy generation from renewable resources because of its sustainability. Hydropower helps emerging markets in particular, because building a hydropower plant is accompanied by infrastructure development, including the construction of roads, waterways, irrigation systems, and even complete economic centers. These activities stimulate the social and economic development of entire regions. This is why hydropower is unique among renewable resources.

**4 Where do you see challenges for hydropower in the near future?**

In a few regions there is currently a reluctance to invest in hydropower, for instance in Europe because of the energy transition, and in the USA because of the current low oil and gas prices. Increasing price pressure caused by intense global competition is a huge challenge for us because of our high levels of research and development expenditure. But there are also encouraging signs, such as the ambitious hydropower program that Canada has adopted. We want to see more of these initiatives to promote hydropower globally.

**5 You worked abroad for many years. How important were those experiences?**

Many years of intercultural cooperation with customers, partners and colleagues in China and Brazil really made an impression on me. Total immersion into other cultures opens one's eyes and promotes intercultural understanding. My experiences in other countries will have a strong influence on my work as a global CMO. I hope everyone can take advantage of similar opportunities. //

---

**Martin Andrä**, after completing his studies in electrical engineering, worked from 1983 to 2000 for Siemens' hydropower division in Germany and Brazil. In 2000, he joined the Board of Management of Voith Siemens Kraftwerkstechnik, before becoming Chairman of the Board in 2003. From 2010 to 2015, he worked in China as the President and CEO of Voith Hydro Shanghai Ltd. Since October 2015, he has led Sales and Marketing worldwide in his role as Executive Vice President and CMO.

---

## KEEPING THE ENERGY FLOWING

Voith has the right people in the right place to meet hydropower challenge globally.

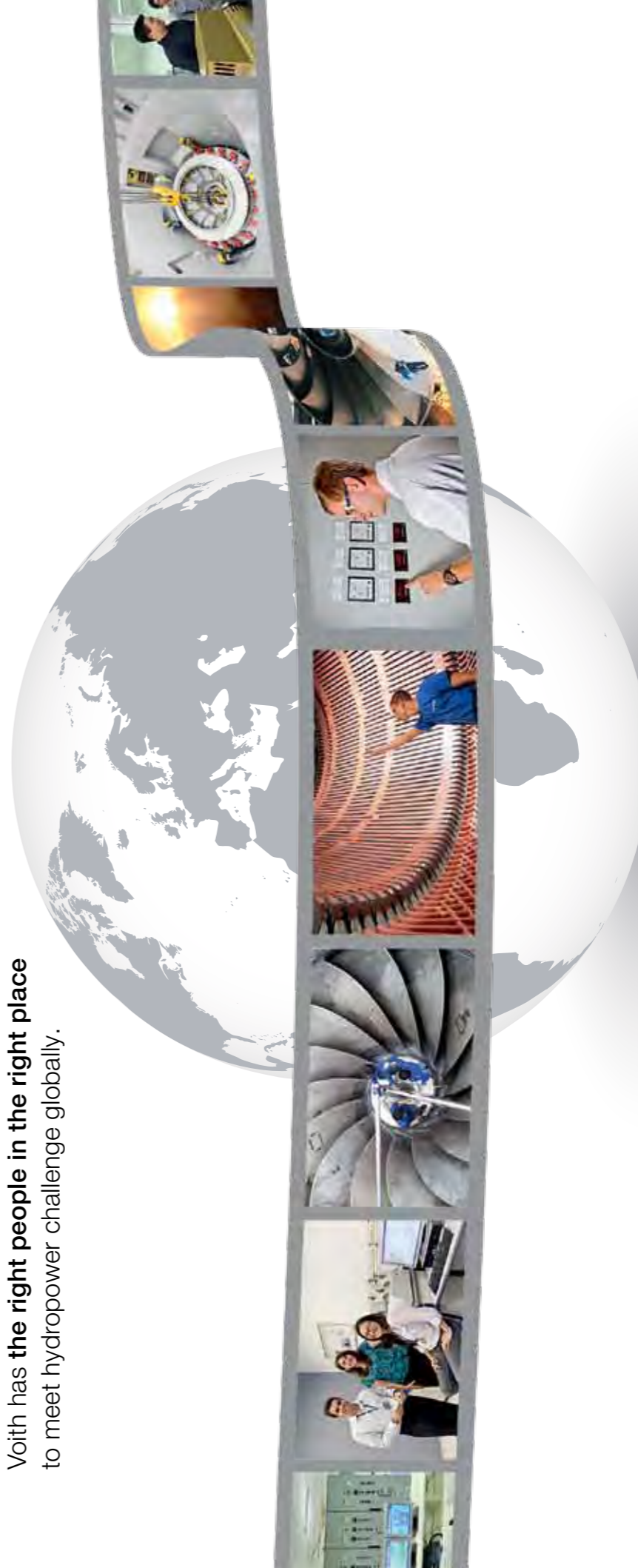

**Hydropower is a global business.** Over the last 150 years, Voith has grown its operations well beyond its German roots by delivering the best possible service to its customers. Today, from Asia to Africa, from Europe to the Americas you can find Voith hydropower machinery in action, and Voith experts helping companies and countries benefit from reliable, renewable energy. Like any industry, constant change and progress is a given. Voith differentiates itself by valuing and utilizing its past, to power the hydropower innovations and solutions for the future.





Customer Magazine by  
Voith Hydro Holding GmbH & Co. KG  
Alexanderstr. 11  
89522 Heidenheim  
Germany  
[www.voithhydro.com](http://www.voithhydro.com)

A Voith and Siemens Company

**VOITH**  
Engineered Reliability