

Modification of Blade Shaft Seals

Depending on the age of your propeller you might need to modify the balking rings between the shaft seal rings of your blade shaft seals. Modern shaft seal rings have an internal reinforcement and must not be used with the old balking rings. The shorter design of modern shaft seal rings requires a modification of the balking rings. Otherwise, serious leakage would occur.

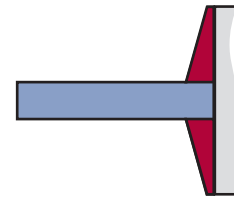
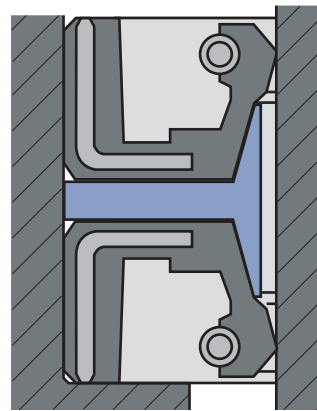

The area marked red has to be removed

If the design of the existing balking rings is similar to the sketch on the right, the area marked red must be removed. After the modification the rings will act as spacer rings.

Possible locations of the spacer ring:

Type A

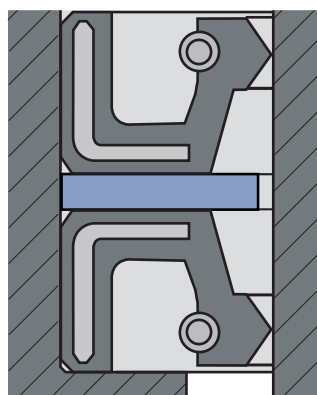

Type B

